

**OPERATOR'S AND UNIT MAINTENANCE MANUAL
(Including Repair Parts and Special Tools List)
FOR
CARTRIDGE, 81MM: TARGET PRACTICE
(SHORT RANGE), M880
NSN 1315-01-216-7071
(1315-C876)**

**DISTRIBUTION STATEMENT A: Approved for public
release; distribution is unlimited.**

This copy is a reprint which includes current pages from
changes 1 through 3.

**HEADQUARTERS DEPARTMENT OF
THE ARMY
JULY 1993**

WARNINGS

DO NOT FIRE CARTRIDGE THROUGH OVERHEAD OBSTRUCTIONS. DO NOT FIRE CARTRIDGE IN TEMPERATURES ABOVE +110°F OR BELOW 0°F.

UPON RELEASING CARTRIDGE, PASS HANDS DOWNWARD AND, AT SAME TIME, TURN AWAY FROM MUZZLE OF MORTAR BARREL TO PRESCRIBED BODY AND HEAD POSITION TO AVOID BLAST WHEN CARTRIDGE FIRES.

IN CASE OF A MISFIRE, REFER TO MISFIRE PROCEDURE IN TM 9-1015-249-10, TM 9-1015-200-10, TM 9-1015-250-10, TM 9-1015264-13&P, OR FM 23-90.

THE MORTAR CREW WILL WEAR SINGLE HEARING PROTECTION DURING FIRING.

RECOVERY IS ONLY AUTHORIZED ON RANGES THAT ARE USED SOLELY FOR TARGET PRACTICE (SHORT RANGE) ROUNDS.

RECOVERY OPERATION WILL NOT TAKE PLACE UNLESS A "CEASE FIRE" IS IN EFFECT.

PERSONNEL MUST WEAR EYE PROTECTION, HEARING PROTECTION, LEATHER WORK GLOVES, DUTY UNIFORM AND HELMET DURING RECOVERY OPERATION.

DO NOT STRIKE NOSE OF FUZE.

IF ANY EXPOSED SKIN HAS A BURNING SENSATION, WASH AFFECTED AREA IMMEDIATELY WITH SOAP AND WATER.

PRIOR TO REFURBISHMENT OPERATION, NEW FUZES MUST BE EXAMINED. DO NOT INSTALL A FUZE WITH A MISSING PACKING CLIP AND/OR RED BAND VISIBLE (STRIKER IS IN THE ARMED POSITION).

b

CHANGE)
)
NO. 3)

HEADQUARTERS
DEPARTMENT OF THE ARMY
Washington, DC, 16 May 1995

**OPERATORS'S AND UNIT MAINTENANCE MANUAL
(Including Repair Parts and Special Tools List)
FOR
CARTRIDGE, 81MM: TARGET PRACTICE (SHORT RANGE), M880**

TM 9-1315-252-12&P, 20 July 1993, is changed as follows:

1. Remove old pages and insert new pages as indicated below. New or changed material is indicated by a vertical bar in the margin of the page.

Remove pages

7 and 8
11 thru 14
101 and 102

Insert pages

7 and 8
11 thru 14
101 and 102

2. File this change sheet in front of the publication for reference purposes.

By Order of the Secretary of the Army:

Official: 

JOEL B. HUDSON
*Acting Administrative Assistant to the
Secretary of the Army*
00306

GORDON R. SULLIVAN
*General, United States Army
Chief of Staff*

Distribution:

To be distributed in accordance with DA Form 12-40-E, Block 0860, requirements for TM 9.1315-252-12&P

CHANGE)
)
NO. 2)

HEADQUARTERS
DEPARTMENT OF THE ARMY
Washington, DC. 29 April 1994

**OPERATORS'S AND UNIT MAINTENANCE MANUAL
(Including Repair Parts and Special Tools List)
FOR
CARTRIDGE, 81MM: TARGET PRACTICE (SHORT RANGE), M880**

TM 9-1315-252-12&P, 20 July 1993, is changed as follows:

1. Remove old pages and insert new pages as indicated below. New or changed material is indicated by a vertical bar in the margin of the page.

Remove pages

13 thru 16

Insert pages

13 thru 16

2. File this change sheet in front of the publication for reference purposes.

By Order of the Secretary of the Army:

GORDON R. SULLIVAN
General, United States Army
Chief of Staff

Official:

MILTON H. HAMILTON
Administrative Assistant to the
Secretary of the Army
06667

Distribution:

To be distributed in accordance with DA Form 12-40-E, Block 0860, requirements for T.M 9-1315-252-12&P

CHANGE)
)
NO. 1)

HEADQUARTERS
DEPARTMENT OF THE ARMY
Washington, DC, 10 August 1993

**OPERATORS'S AND UNIT MAINTENANCE MANUAL
(Including Repair Parts and Special Tools List)
FOR
CARTRIGE, SIMM: TARGET PRACTICE (SHORT RANGE), MO80**

TM 9-1315-252-12&P, 20 July 1993, is changed as follows:

1. Remove old pages and insert new pages as indicated below. New or changed material is indicated by a vertical bar in the margin of the page.

Remove pages

35 and 36
None

Insert pages

35 and 36
36.1 and 36.2

2. File this change sheet in front of the publication for reference purposes.

By Order of the Secretary of the Army:

GORDON R. SULLIVAN
General, United States Army
Chief of Staff

MILTON H. HAMILTON
Administrative Assistant to the
Secretary of the Army
05067

Distribution:

To be distributed in accordance with DA Form 12-40-E, Block 08GO, requirements for TM 9-1315-252-12&P

***TM 9-1315-252-12&P**

TECHNICAL MANUAL

No. 9-1315-252-12&P

HEADQUARTERS
DEPARTMENT OF THE ARMY
Washington, DC, 20 July 1993

**Operator's and Unit and Maintenance Manual
(Including Repair Parts and Special Tools List)
for
Cartridge, 81MM: Target Practice (Short Range), M880
NSN 1315-01-216-7071
(1315-C876)**

REPORTING ERRORS AND RECOMMENDING IMPROVEMENTS

You can help improve this manual. If you find any mistakes, or if you know of a way to improve the procedures, please let us know. Mail your letter or DA Form 2028 (Recommended Changes to Publications and Blank Forms) directly to Commander, U.S. Army Armament Research, Development and Engineering Center, ATTN: SMCAR-LSB, Picatinny Arsenal, New Jersey 07806-5000. A reply will be furnished to you.

*This manual supersedes TM 9-1315-252-12&P, dated 28 February 1992.

CHAPTER 1.	INTRODUCTION	
Section I.	General Information	5
Section II.	Ammunition Description	7
Section III.	Principles of Operation	16
CHAPTER 2.	OPERATING INSTRUCTIONS	
Section I.	Safety Requirements	21
Section II.	Preparation for Firing.....	22
Section III.	Loading and Firing.....	26
Section IV	Recovery	30
Section V	Refurbishment	40
CHAPTER 3.	REPAIR MORTAR DEFUZING TOOL	
Section I.	Inspection	63
Section II.	Disassembly of Mortar Defuzing Tool Components	66
Section III.	Reassembly of Mortar Defuzing Tool Components	69
CHAPTER 4.	MAINTENANCE INSTRUCTIONS	
Section I.	Weapon	73
Section II.	Ammunition	73
Section III.	Mortar Defuzing Tool, Breech Plug Tool	73

APPENDIX A.	REFERENCES.	75
APPENDIX B.	REPAIR PARTS AND SPECIAL TOOLS LIST	79
APPENDIX C.	EXPENDABLE/DURABLE SUPPLIES AND MATERIALS LIST	101

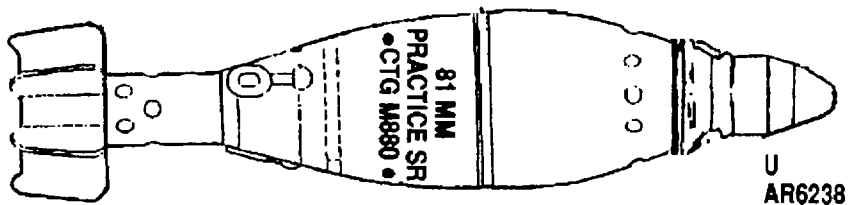

Cartridge, 81mm: Target Practice (Short Range), M880.

CHAPTER 1 INTRODUCTION

SECTION I. GENERAL INFORMATION

SCOPE

This manual provides operating instructions for Cartridge, 81mm: Target Practice (Short Range), M880. Included are procedures for preparing, loading, firing, recovering and refurbishing ammunition. This publication is to be used in conjunction with TM 9-1015-249-10, Operator's Manual for Mortar 81mm: M252; TM 9-1015-200-10, Operator's Manual for Mortar 81mm: M29A1; TM 9-1015-254-13&P, 81mm Subcaliber Insert; or TM 91015-250-10, Operator's Manual for Mortar, 120mm Towed M120 and Mortar, 120mm Carrier-Mounted M121.

MAINTENANCE FORMS AND RECORDS

Department of Army forms and procedures used for equipment maintenance will be those prescribed by DA PAM 738-750 (The Army Maintenance Management System(TAMMS)).

REPORT OF DAMAGED OR IMPROPER SHIPMENT

Damaged or improper shipments will be reported immediately using SF 364 (Report of Discrepancy (ROD)), SF 361 (Transportation Discrepancy Report), and AR 55-38 (Report of Transportation Discrepancies in Shipments).

MALFUNCTION REPORTS

A malfunction is a failure of cartridge to perform as expected when fired. Malfunctions do not include accidents or fires from negligence or misuse. Reporting procedures are prescribed in AR 75-1 (Malfunctions Involving Ammunition and Explosives).

ACCIDENT REPORTS

Accidents involving injury to personnel or damage to materiel are reported on DA Form 285 (U.S. Army Accident Report) in accordance with AR 385-40 (Accident Reporting and Records).

FIRE REPORTS

DD Form 2324-1 (DOD Summary No Loss Fire Emergencies Report) or DD Form 2324 (DOD Fire Incident Report) will be used to report fired or explosions followed by fire. DD Form 2324-1 or DD Form 2324 will be submitted in addition to accident reports required by AR 385-40.

SECTION II. AMMUNITION DESCRIPTION

AMMUNITION CHARACTERISTICS, CAPABILITIES AND FEATURES

Cartridge, 81mm: Target Practice (Short Range), M880 can be fired from 81mm M252 Mortar or 81mm M29 (Series) Mortar using standard sight/fire control equipment and firing table FT 81-AR-1, C4.

Training cartridge can be fired to a maximum distance of 458 meters. On impact with ground or target, fuze produces a visible flash, a cloud of smoke and an audible sound for spotting purposes.

The spent (fired) projectiles can be recovered for refurbishment and reuse.

LOCATION AND DESCRIPTION OF MAJOR COMPONENTS

Cartridge, 81mm: Target Practice (Short Range), M880 is composed of the following:

- (1) Fuze, point detonating (practice), M775.
- (2) Projectile body.
- (3) Obturating ring.
- (4) Plastic plugs (simulated increments).
- (5) Dud plugs.
- (6) Fin assembly.
- (7) Ignition (propelling) cartridge, M986.
- (8) Breech plug assembly.

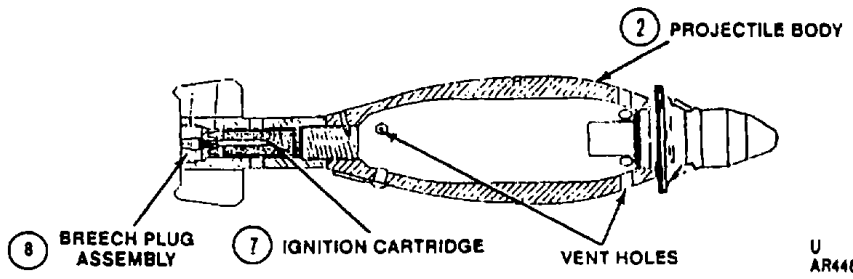
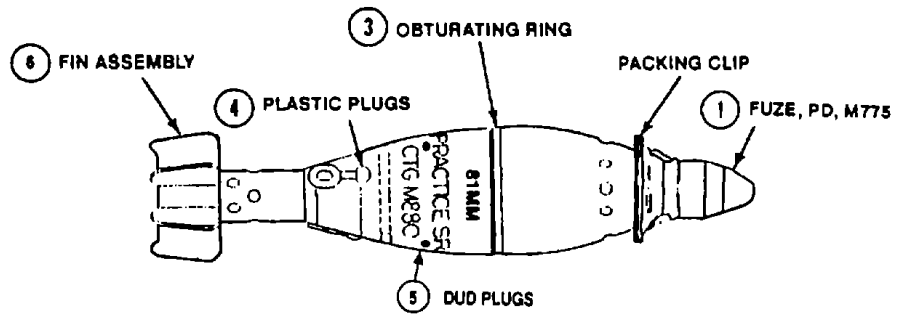

U
AR4460-A

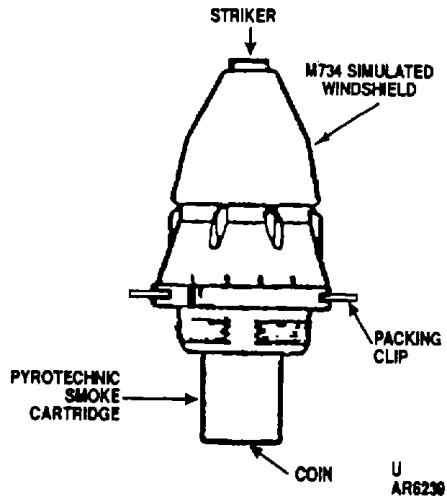

(1). M775 PD FUZE

- Produces a visible flash, a cloud of smoke, and an audible sound on impact for spotting purposes.
- Has multi-option type (PRX/NSB/IMP/DLY) dummy settings to simulate an M734 multi-option fuze.

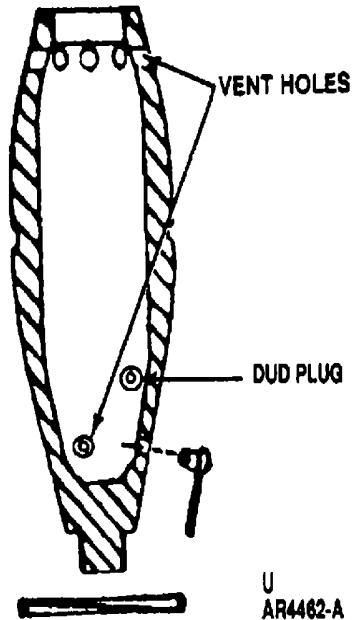

(2). PROJECTILE BODY

- Cast iron metal.
- Hollow (empty).
- Has VENT HOLES which allow gases to escape the mortar barrel (through shell) for reduced range.

(3). OBTURATING RING

- Split ring.
- Expands outward to prevent gases from escaping around projectile body.

(4). PLASTIC PLUGS (SIMULATED INCREMENTS)

- Regulates amount of gas allowed to vent through projectile body for range adjustment.

(5). DUD PLUGS

- Plastic plug.
- When fuze functions, all three dud plugs are expelled out of projectile body.

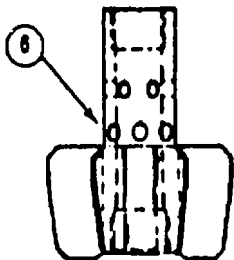

(6). FIN ASSEMBLY

- Aluminum metal.
- Stabilizes projectile in flight.

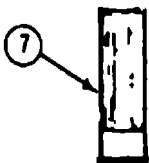

(7). M985 IGNITION CARTRIDGE

- Propels projectile downrange.
- Contains propellant and has a percussion primer.



(8). BREECH PLUG ASSEMBLY

- Retains ignition cartridge in fin assembly housing.
- Has a firing pin.

U
A11483-A

AMMUNITION DATA

Cartridge:

Weight	6.84 lb
Length	14.5 in.
Type/use	Target Practice (Short Range)/Training
Identification	Blue with white markings and one brown band
Maximum range	458 m (501 yd)
Temperature Limits:	
Firing	0°F (-18°C) to +110°F (+43°C)
Storage	Do not store at or below -45°F (-43°C) for period of more than 3 days or at above +145°F (+63°C) for period of more than 4 hrs/day
Pack	1 cartridge in fiber container; 8 containers in wirebound box
Packaging (wirebound box):	
Total weight	77lb
Dimensions	19.5 x 16 x 9.5 in.

Shipping and Storage Data:

Hazard class	1.4
Storage compatibility group	S
DOT shipping class	CLASS C EXPLOSIVE
DOT designation	CARTRIDGES, PRACTICE
	AMMUNITION
NSN	1316-01-216-7071
DODAC	1315-C876

Refurbishment Kit.

Components	Fuze, PD M775 (1 per kit); ignition cartridge, M985 (1 per kit); obturating ring (1 per kit); plastic plugs (3 per kit); breech plug assembly (1 per kit); dud plugs (3 per kit).
Pack	Each kit is packed in a corrugated fiberboard (water resistant) carton. 25 cartons are packed into a corrugated fiberboard box. Each fiberboard box is

contained in a sealed barrier bag. Four fiberboard boxes are packed into a wirebound box.

Packaging Box:

Total weight
Dimensions
Temperature limit (storage)

117.2 lb (2-man carry is required)
40-1/8 x 20-1/16 x 14-1/4 in.
Do not store at or below -45°F (-43°C)
for period of more than 3 days or at
above +145°F (+63°C) for period of
more than 4 hrs/day

Shipping and Storage Data:

Hazard class
Storage compatibility group
DOT shipping class
DOT designation

NSN
DODAC.....

1.4
G
CLASS C EXPLOSIVE
SPECIAL FIREWORKS - HANDLE
CAREFULLY; KEEP FIRE AWAY
1315-01-219-3936
1315-C045

SECTION III. PRINCIPLES OF OPERATION

1. Cartridge is inserted (loaded) into mortar barrel (fin-end first) and released.
2. Cartridge slides down mortar barrel and strikes firing pin at bottom.

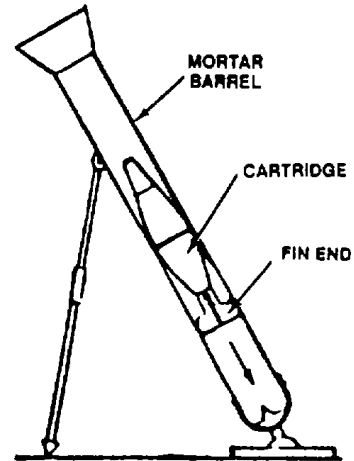

U
AR 4484

3. Firing pin of breech plug assembly strikes percussion primer of ignition cartridge. Primer functions. The propellant ignition cartridge is ignited.
4. Burning propellant produces gas.

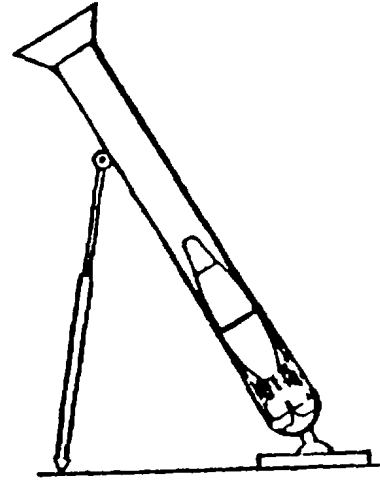

U
AR 4465

5. Propellant GAS EXPANDS and propels cartridge up mortar barrel.
6. Removal of plastic plug(s) from projectile body (prior to firing) allows some of propellant gas to escape. Gas enters projectile body through rear hole(s) through projectile body, exits forward vent holes, and out open end of mortar barrel. This reduces range of cartridge.

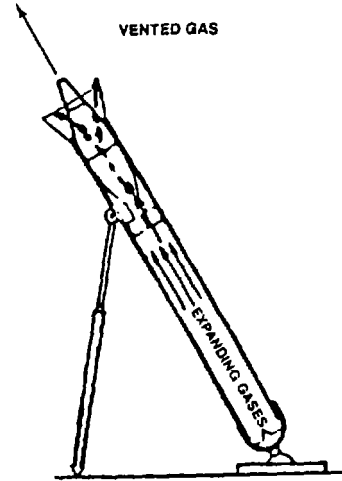

U
AR 4466

7. Fuze arms during forward acceleration when SETBACK PIN moves rearward. This allows SLIDER to move radially outward. The STRIKER is released and a steel ball is inserted between striker and primer of PYROTECHNIC SMOKE CARTRIDGE. As illustrated, the arrows show the direction of movement.

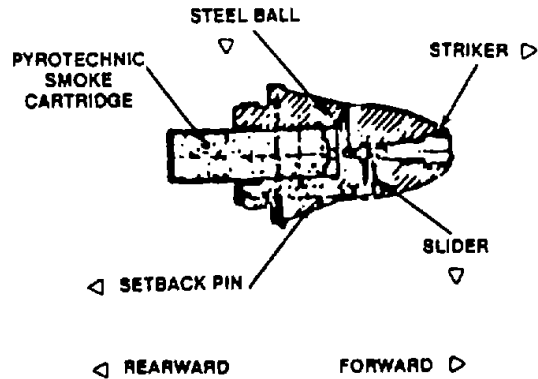

U
AR 4467

8. Cartridge leaves barrel and travels downrange. The fin assembly stabilizes its flight.
9. Fuze functions upon impact with ground (target). Striker drives steel ball into primer of pyrotechnic smoke cartridge. Smoke cartridge produces a visible flash, a cloud of smoke, and an audible sound. Dud plugs are expelled from projectile.

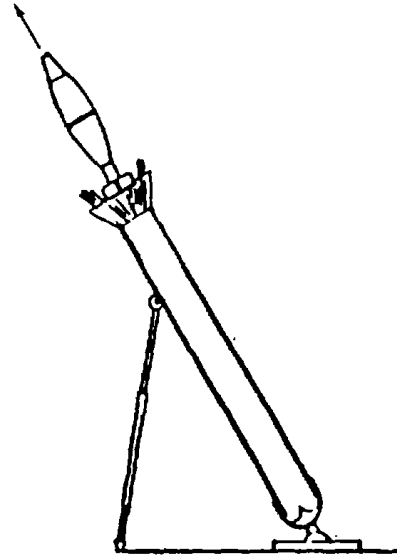

U
AR 4468

CHAPTER 2
OPERATING INSTRUCTIONS

SECTION I. SAFETY REQUIREMENTS

Cartridge, 81 mm: Target Practice (Short Range), M880 can be fired on the following types of ranges:

- Standard ranges where service ammunition is fired.
- Designated ranges for TP (SR) cartridges only.

Recovery is only authorized on ranges that are used solely for TP (SR) rounds.

Recovery is not authorized in areas where high explosive (HE) dud projectiles may exist.

AR 385-63 (Policies and Procedures for Firing Ammunition for Training, Target Practice and Combat) shall be followed when firing Cartridge, 81mm: Target Practice (Short Range), M880.

Firing over heads of unprotected troops is prohibited.

Safety Fan - The surface danger zone shall be established in accordance with AR 385-63.

Ranges must be cleared after firing and certified clean.

SECTION II. PREPARATION FOR FIRING

1. Unpack cartridge.

NOTE

- **Save packaging materials (for reuse).**
- **If weather is such that packaging may be damaged (e.g., rain), it should be protected.**

- Do not remove packing clip until just prior to firing.
- If any dud plug(s) are missing from cartridge, place cartridge into dud pit.

2. Examine fuze. Fuze may be armed if packing clip is missing or red band on striker is protruding from nose cap. Do not attempt to fire a cartridge with an armed fuze. Carefully lay cartridge in dud pit without striking nose of fuze.

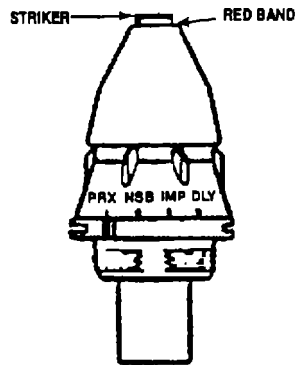

Armed fuze.

U
AR4480-A

3. Set fuze for specified type of burst.

NOTE

- **Fuze shall not be prepared until fire mission is given.**
- **M775 PD fuze functions on impact with superquick action only. Setting of fuze is for practice only and has no effect upon actual functioning.**

4. Remove proper number of plastic plugs (simulated increments) from projectile body for desired charge. The following chart shows number of plugs that should be remaining for each charge:

Charge 0 - No plugs. Charge 1 - One plug remaining on the body. Charge 2 - Two plugs remaining on the body. Charge 3 - Three plugs remaining on the body

M734 MULTI-OPTION (SIMULATED) HEAD

Rotate plastic windshield in clockwise direction, by hand, until correct marking (PRX, NSB, IMP or DLY) is over index line.

PRX = Proximity

NSB = Near surface burst

IMP = Impact

DLY = Delay

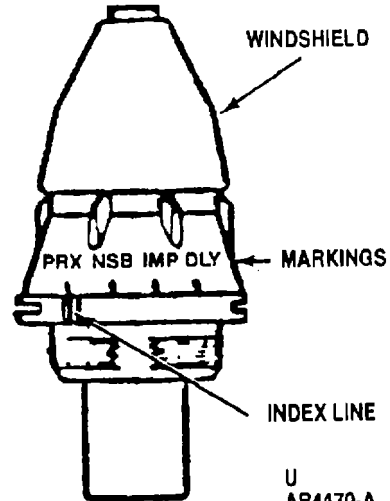

SECTION III. LOADING AND FIRING

WARNING

- **DO NOT FIRE CARTRIDGE THROUGH OVERHEAD OBSTRUCTIONS.**
- **DO NOT FIRE CARTRIDGE IN TEMPERATURES ABOVE 110°F OR BELOW 0°F.**
- **UPON RELEASING CARTRIDGE, PASS HANDS DOWNWARD AND, AT SAME TIME, TURN AWAY FROM MUZZLE OF MORTAR BARREL TO PRESCRIBED BODY AND HEAD POSITION TO AVOID BLAST WHEN CARTRIDGE FIRES.**
- **IN CASE OF MISFIRE, THERE ARE NO SPECIAL PROCEDURES ASSOCIATED WITH M880 CARTRIDGE. REFER TO MISFIRE PROCEDURES IN TM 9-1015-249-10 (FOR**

81MM M252 MORTAR), TM 9-1015-200-10 (FOR 81MM M29A1 MORTAR), TM 9-1015-254-13&P (81MM SUBCALIBER INSERT), TM 9.1015-250-10 (FOR 120MM M120 TOWED MORTAR AND 120MM M121 CARRIER-MOUNTED MORTAR) OR FM 23-90.

- **THE MORTAR CREW SHALL USE SINGLE HEARING PROTECTION DURING FIRING.**

CAUTION

BEFORE LOADING, ENSURE THAT CARTRIDGE AND BORE OF MORTAR BARREL ARE FREE OF SAND, MUD, MOISTURE AND SNOW.

LOADING

1. Remove packing clip from fuze. Do not discard clip until cartridge has been fired. Clip will be needed if cartridge is not fired and must be repackaged.
2. Insert cartridge into mortar barrel (fin-end first).
3. Release cartridge in proper manner on command to fire.

Cartridge will slide down barrel under its own weight, strike firing pin at bottom, and fire.

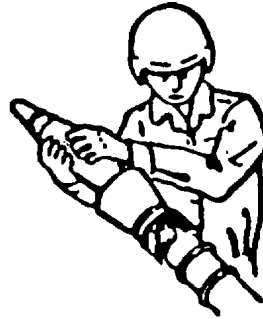

U
AR 4471

FIRING

1. See firing table (FT 81-AR-1, C4) for expected ranges at various elevations.
2. Forward observer (FO) must be in position prior to firing. The FO will observe impact of round (smoke, bang, and flash).
3. Refer to FM 23-91 (Mortar Gunnery) and FM 6-30 (The Field Artillery Observer) for fire adjustment procedures.

LOG BOOK ENTRIES (WEAPON)

1. At the end of a day's firing, record number and type of rounds fired on DA Form 2408-4 (Weapon Record Data).

UNFIRED CARTRIDGES

1. Reinsert packing clip into wrench slots of fuze.

2. Reinstall plastic plugs (simulated increments), if any were removed from projectile body.
3. Repackage the cartridge.

SECTION IV RECOVERY

WARNING

- **RECOVERY IS ONLY AUTHORIZED ON RANGES THAT ARE USED SOLELY FOR TP (SR) ROUNDS.**
- **RECOVERY OPERATIONS WILL NOT TAKE PLACE UNLESS A "CEASE FIRE" IS IN EFFECT.**
- **DO NOT STRIKE NOSE OF FUZE.**

- **PERSONNEL MUST WEAR EYE PROTECTION, HEARING PROTECTION AND LEATHER WORK GLOVES (IN ADDITION TO DUTY UNIFORM WITH HELMET) DURING RECOVERY OPERATION.**
- **AFTER SPLITTING FUZE OF A DUD PROJECTILE IN THE MORTAR DEFUZING TOOL (KNOWN AS THE DEFUZING DEVICE), IF SPOTTING CHARGE CANNOT BE EASILY REMOVED BY HAND DO NOT ATTEMPT TO REMOVE CHARGE WITH TOOLS. REJECT ENTIRE CARTRIDGE AND PLACE IN DUD PIT.**

GENERAL

Cartridge, 81mm: Target Practice (Short Range), M880 can be recovered for refurbishment and reuse at end of firing. Recovery and refurbishment of spent (fired) projectiles is only authorized if firing:

- On a designated TP (SR) firing range.
- A "cease fire" is in effect.

Factors that will affect recoverability are target area terrain, manpower, time constraints, weather conditions, etc. It is recommended that recovery of spent projectiles be performed on same day as firing, to aid in locating and identifying items. In any case, recovery must be accomplished within 24 hours to assure components may be disassembled.

All spent projectiles **MUST** be recovered and holes filled in if firing is on a temporary range (field).

Because of their low velocity, it is expected that most of the TP (SR) rounds can be found by looking for fin assemblies sticking out of the ground. If rounds are completely buried, their location can be determined by sighting entry holes or disturbed dirt.

A section of the mortar platoon should be directed to move downrange in accordance with Range Control procedures; locate spent (fired) projectiles; extract projectile and defuze any dud projectiles prior to returning to refurbishment site. Remainder of platoon will be utilized for refurbishment operation.

EQUIPMENT

The following equipment must be available to support the recovery operation:

- Grappling tools
- Mortar defuzing tool
- Shovels
- Defuzing tool base (locally fabricated, plywood, size 3/4 x 24 x 32 in.)
- Eye protection
- Ear plugs
- Leather gloves

Necessary items (with exception of shovels) are provided in Tool Kit, Recovery and Refurbishment (NSN 5180-01-348-3081).

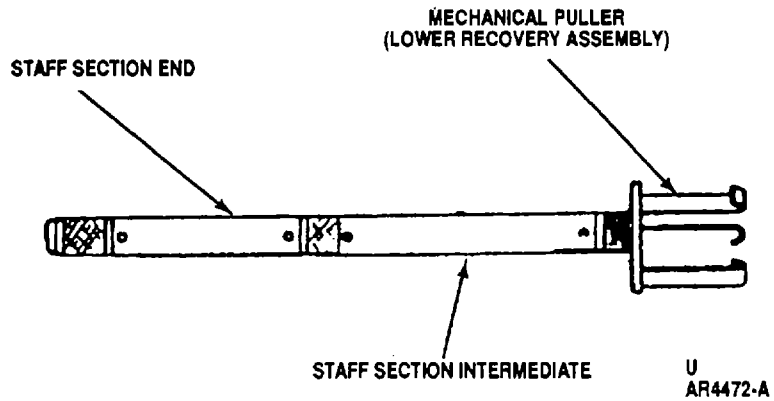

Grappling tool.

RECOVERY PROCEDURE

1. Verify that all firing into target area has completely stopped and a "cease fire" is in effect.
2. Assemble grappling tools (if necessary).
3. A recovery team outfitted with personnel protective equipment (i.e., eye protection, duty uniform, hearing protection, and leather gloves) will be designated to move downrange.
4. Move downrange and search impact area for spent (fired) projectile(s).

CAUTION

AVOID STRIKING PROJECTILE IF A SHOVEL IS USED TO EXPOSE FIN ASSEMBLY.

5. Recovery of projectiles that are partially or completely buried:
 - a. Use a shovel to expose enough of round, grasp projectile by fins, then remove it by hand or with grappling tool (if necessary).
 - b. Visually inspect for presence of dud plugs. If round is buried, dig around cartridge until dud plug holes are visible.
 - c. Second person must verify that dud plugs have been expelled.
 - (1) If no dud plugs are visible on projectile body, place projectile in wooden box for transport to refurbishment site and refill all holes.
 - (2) If any dud plugs remain in projectile, place cartridge into mortar defuzing tool (known as defuzing device) and defuze before refurbishing.

WARNING

IF SPOTTING CHARGE CANNOT BE EASILY REMOVED BY HAND, DO NOT ATTEMPT TO REMOVE CHARGE WITH TOOLS. REJECT ENTIRE CARTRIDGE AND PLACE IN DUD PIT.

DEFUZING PROJECTILE

1. Open mortar defuzing tool (known as defuzing device).
2. Place projectile in defuzing tool in proper orientation with a packing clip groove facing upward.
3. Put cover on defuzing tool and insert locking pins.

☆U.S. GOVERNMENT PRINTING OFFICE: 1994 - 300-421/82798

Change 1 36.2

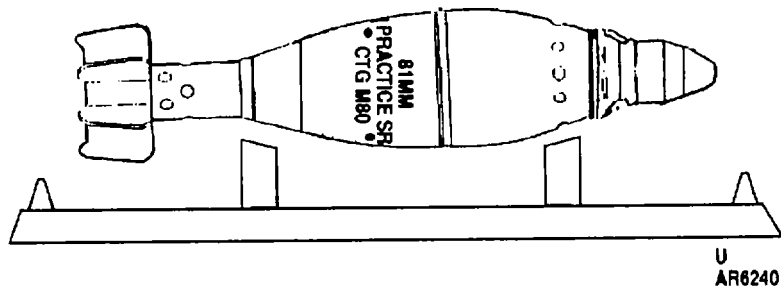

Fired cartridge to defuzing tool.

4. Assure side of defuzing tool with holes is facing away from all personnel.
5. Disable fuze by striking disarming assembly with hammer until chisel moves freely under spring.

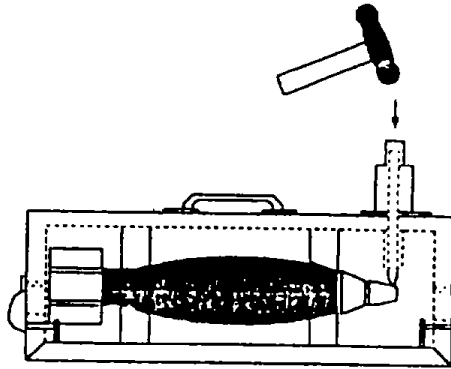

U
AR 4475

NOTE

Upon opening defuzing tool, verify spotting charge has functioned.

- If charge is discolored, then function has occurred. Projectile is then transported to refurbishment site.
- If charge is not discolored, then remove spotting charge, place in container and transport spotting charge to dud pit.

SECTION V. REFURBISHMENT

CAUTION

SPENT (FIRED) PROJECTILES WILL BE DISASSEMBLED/REFURBISHED IN A WELL VENTILATED AREA.

NOTE

If projectile is not to be refurbished immediately after recovery, then disassemble, clean and lightly coat projectile body and fin assembly threads with protective oil to prevent corrosion. Oil is to be wiped off prior to refurbishment.

GENERAL

Fuze, plastic plugs (simulated increments), breech plug assembly, dud plugs, obturating ring, and ignition cartridge must be replaced before spent (fired) cartridge can be refired. All of the necessary replacement parts are provided in refurbishment kit (NSN 1315-01-219-3936).



FUZE



PLASTIC PLUGS
(3 EACH)



BREECH
PLUG
ASSEMBLY



DUD PLUGS
(3 EACH)



OBTURATING RING



IGNITION
CARTRIDGE

U
AR4476

EQUIPMENT AND MATERIAL

The following tools/equipment and material are needed to refurbish spent (fired) projectiles:

- Wrench, pipe (strap)
- Wrench, spanner (fin)
- Tool, breech plug
- Block, cartridge (for removing ignition cartridge)
- Punch, drive pin (81mm)
- Hammer, hand (ball-peen)
- Channel lock pliers
- Rags, cotton
- Garbage cans, 10 gallons
- Gloves, chemical and oil protective
- Screwdriver, flat-tip
- Punch drive, pin

Necessary items (with exception of garbage cans, work tables, and rags) are provided in Tool Kit, Recovery and Refurbishment (NSN 5180-01-3483081).

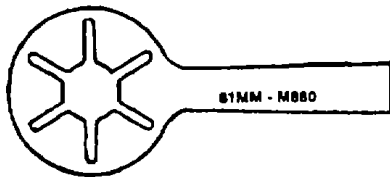

WRENCH, SPANNER (FIN)



PUNCH, DRIVE PIN (81MM)

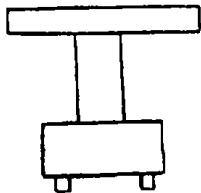

TOOL, BREECH PLUG

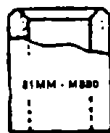

BLOCK, CARTRIDGE

U
AR4477-B

SET-UP

1. Position at least two work (field) tables at designated refurbishment area. One table will be used for disassembly operation; the other table will be used for assembly operation.
2. Place three empty garbage cans near disassembly workstation. Garbage cans will be used for washing reusable parts (projectile body and fin assembly) and collecting discarded parts.
3. Place empty fiber containers and wirebound (ammunition) boxes near assembly workstation for repacking refurbished cartridges.

DISASSEMBLY PROCEDURE

WARNING

IF ANY EXPOSED SKIN HAS A BURNING SENSATION, WASH AFFECTED AREA IMMEDIATELY WITH SOAP AND WATER.

NOTE

Dud plug(s) will be present on defuzed projectiles.

1. Check recovered projectile for presence of dud plug(s). If all dud plugs expelled, place in water and clean projectile.
2. If some dud plugs were not expelled from projectile body, return projectile to defuzing tool to disable fuze.

3. Place projectile on work table and check for presence of dud plugs. Use strap wrench to secure projectile, if required.
4. Remove fuze using channel lock pliers. Rotate fuze counterclockwise (to left). Verify coin has blown out of the base of fuze.
 - a. If fuze coin has not blown out, immediately thread fuze back into projectile and transport to defuzing tool to defuze.
 - b. If fuze has functioned, discard remainder of fuze into trash container.

5. Remove breech plug assembly and fin assembly.
 - a. Loosen breech plug assembly using breech plug tool. Pins of wrench engage hole in breech plug. Rotate breech plug counterclockwise (to left).

NOTE

If breech plug assembly cannot be removed from fin, dispose of complete projectile in accordance with local Standard Operating Procedures (SOP).

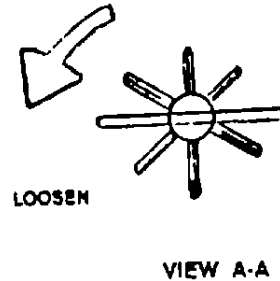
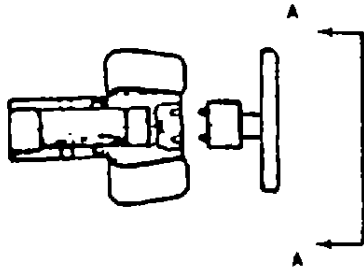

U
AR 4481

- b. Unscrew loosened breech plug assembly, by hand, and remove. Discard breech plug assembly into trash container.
- c. Loosen fin assembly using fin wrench. Slotted end of wrench engages fins. Rotate fin assembly counterclockwise (to left).
- d. Unscrew loosened fin assembly, by hand, and remove.

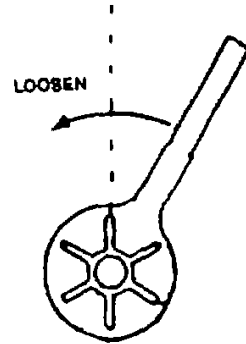
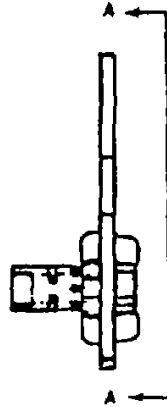

VIEW A-A

U
AR 4482

6. Remove spent (fired) ignition cartridge from fin assembly.

- a. Place fin assembly (fin down) on top of block.
- b. Use hammer and drive pin punch to drive out ignition cartridge. Insert punch end into open end of fin. Tap punch until ignition cartridge drops out of fin assembly. Discard ignition cartridge into trash container.

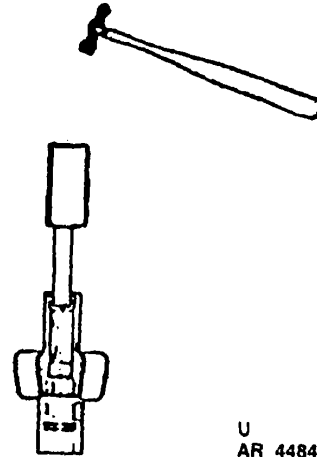

U
AR 4484

7. Remove remaining plastic plugs (simulated increments) and old obturating ring (if present) from projectile body using screwdriver. Discard remaining plastic plugs and/or old obturating ring into trash container.

8. Remove dud plugs (if present) from projectile body by placing drive pin punch on center of dud plug and tap lightly on punch with hammer. Discard remaining dud plug(s) into trash container.

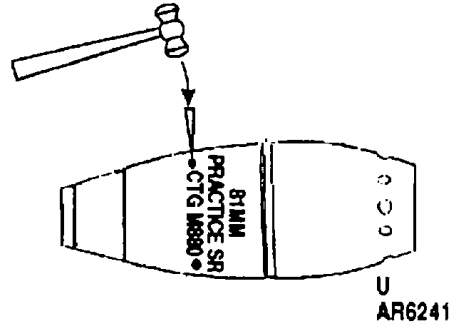

ASSEMBLY PROCEDURE

WARNING

IF ANY EXPOSED SKIN HAS A BURNING SENSATION AT ANY STEP OF REFURBISHMENT PROCEDURE, WASH AFFECTED AREA IMMEDIATELY WITH SOAP AND WATER.

1. Thoroughly clean projectile body and fin assembly with water. Remove as much dirt and spotting charge residue as possible. Use a wire bristle brush to clean exterior of projectile body and fin assembly. Clean vent holes (forward and rear), dud plug holes, fuzewell threads of projectile body, ignition cartridge housing and internal threads of fin assembly with a small arms cleaning brush.

2. Using clean rags, thoroughly dry projectile body, fin assembly and all threads.
3. Visually inspect projectile body and fin assembly. If damaged (dents, cracks or gouges), projectile will be rejected. Dispose of damaged component in accordance with local SOP

NOTE

- **If cartridge will not be refurbished at this time, coat projectile and threads with a light coat of oil and repackage in accordance with step 12.**
 - **Any items that cannot be properly reassembled will be rejected.**
4. Open refurbishment kit. If fuze packing clip is missing or if striker is in armed position (red band is visible), place complete kit in dud pit.

5. Assemble fin assembly to projectile body.
 - a. Screw fin assembly onto projectile body, by hand, until it fully seats against base. Rotate fin assembly clockwise (to right).
 - b. Secure fin assembly handtight.
6. Install three plastic plugs (increments) into rear vent holes, tangs pointing rearward of projectile body.
7. Install three dud plugs in counter sunk holes of projectile body.

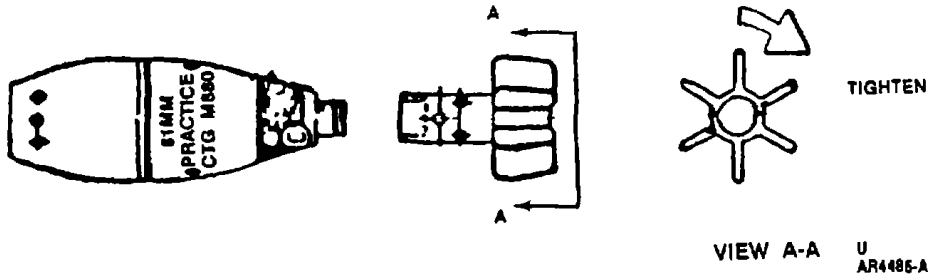

8. Install obturating ring to projectile body.
 - a. Slide obturating ring down nose end of projectile body, as illustrated.
 - b. Expand ring until it snaps into groove in body.
 - c. Visually observe that obturating ring is flush or below surface of projectile body. If ring is above flush, remove ring, check/re-clean groove, and reseat. If still above, obtain a second obturating ring from another refurbishment kit. Install second obturator ring onto projectile body. If second obturating ring does not seat correctly, remove obturating ring and previously installed plastic plugs and dud plugs. Dispose of projectile body as unserviceable in accordance with local SOP

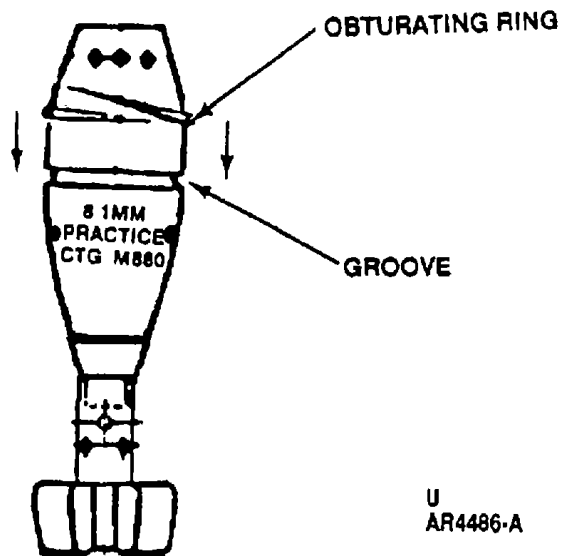

U
AR4486-A

9. Install ignition (propelling) cartridge.

- a. Insert ignition cartridge (primer end last) into housing of fin assembly, as illustrated.
- b. Do not use any tools to force ignition cartridge into housing. If ignition cartridge does not enter freely, clean housing and re-insert.
- c. If ignition cartridge does not enter freely after recleaning, cartridge shall be rejected.

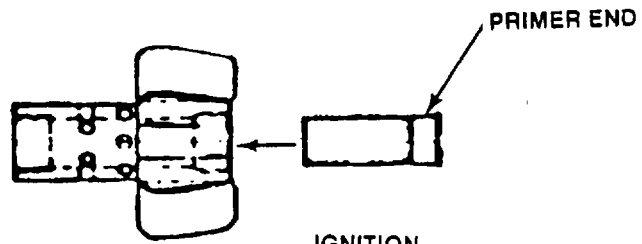

IGNITION
CARTRIDGE

U
AR 4488

NOTE

Assure that firing pin is in place and can be moved freely before installing breech plug assembly

10. Install breech plug assembly.
 - a. Assemble breech plug assembly into end of fin assembly, by hand, as illustrated. Rotate breech plug assembly clockwise (to right).
 - b. Apply 1/4 turn rotation with breech plug tool until breech plug assembly is seated.

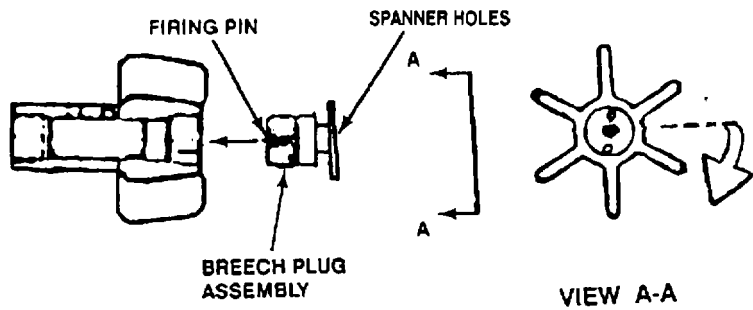

TIGHTEN

U
AR4489-B

11. Install fuze to projectile body.

- a. Set projectile on worktable in horizontal position.
- b. Hold projectile body using strap wrench, if required.
- c. Assemble fuze to nose of projectile, by hand, in clockwise (to right) position until it fully seats against nose of projectile.
- d. Secure fuze handtight.

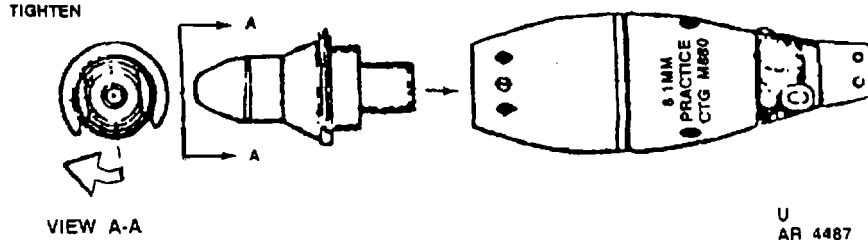

U
AR 4487

CAUTION

DO NOT REPACK CARTRIDGE IF PACKING CLIP IS MISSING.

12. Repack cartridges in fiber containers and wirebound boxes (if desired) that were saved from previous firing.
 - a. Assure that fuze has a packing clip.
 - b. Insert cartridge into fiber container, fuze-end first.
 - c. Install container cover of fiber container.

- d. Pack eight cartridges/fiber containers into a wirebound box. Alternate cover end of fiber containers to evenly distribute weight.
 - e. Close lid of wirebound box, secure with wire loops, and return to firing range.
13. Unused (new) cartridges and extra refurbishment kits shall to returned to ASP at end of exercise.

CHAPTER 3
REPAIR MORTAR DEFUZING TOOL

SECTION I. INSPECTION

The mortar defuzing tool (known as the defuzing device) should be inspected for cracked, broken, and/or loose parts when hand receipted. Inspection includes defuzing tool body (box), bail handle, disarming assembly, or other parts. If any items are damaged, replace with parts from kits.

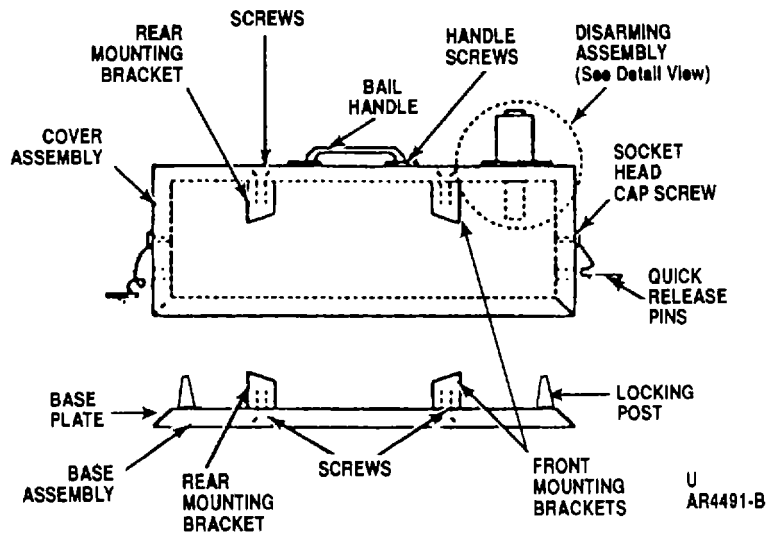

Mortar Defuzing Tool.

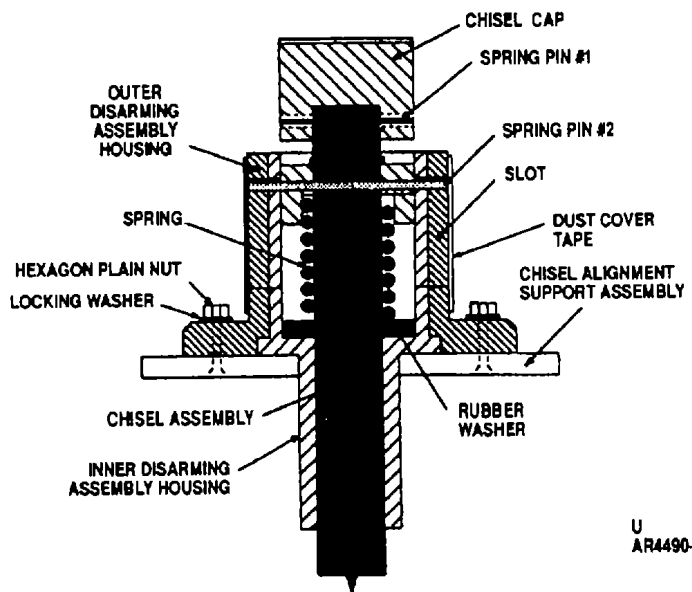

U
 AR4490-A

Disarming Assembly.

SECTION II. DISASSEMBLY OF MORTAR DEFUZING TOOL COMPONENTS

CHISEL ASSEMBLY AND CHISEL CAP

1. Remove spring pin No. 1 from chisel cap by using hammer and drive pin punch.
2. Remove spring pin No. 2 from disarming assembly by using hammer and drive pin punch.
3. Remove chisel cap, chisel assembly, spring, and rubber washer from disarming assembly.

DISARMING ASSEMBLY

1. Remove chisel assembly in accordance with steps above.
2. Unscrew four machine screws, nuts, and locking washers counterclockwise (to left) from disarming assembly by using 3/8-inch hex key wrench.
3. Remove disarming assembly from defuzing tool body.

BAIL HANDLE

1. Unscrew five handle screws counterclockwise (to left) on bail handle by using 1/8-inch hex key wrench.
2. Remove bail handle from defuzing tool body.

SOCKET HEAD CAP SCREW AND QUICK RELEASE PINS

1. Remove socket head cap screw counterclockwise (to left) on side of defuzing tool body by using 3/16-inch hex key wrench.
2. Remove connecting wires and two quick release pins on side of defuzing tool body.

FRONT AND REAR MOUNTING BRACKETS (known as Front and Rear Supports)

1. Turn defuzing tool upside down.
2. Unscrew two screws counterclockwise (to left) for each mounting bracket by using 3/16-inch hex key wrench.
3. Remove front or back mounting bracket from base of defuzing tool body.

KIT NO. 1 CONTAINS:

- (1) Chisel cap
- (2) Chisel assembly
- (3) Spring
- (4) Washer, rubber
- (5) Pin, spring, No. 1
- (6) Pin, spring, No. 2

KIT NO. 2 CONTAINS:

- (1) 3/8-16-2A x 1-1/2 inch screws (4 each)
- (2) Washers, locking (4 each)
- (3) 3/8-inch nut (4 each)
- (4) Disarming assembly (inner and outer housing)

SECTION III. REASSEMBLY OF MORTAR DEFUZING TOOL COMPONENTS

CHISEL ASSEMBLY AND CHISEL CAP WITH KIT NO. 1

1. Place rubber washer into disarming assembly.
2. Place spring over chisel assembly.
3. Place chisel assembly into disarming assembly.
4. Align slot in disarming assembly with chisel assembly hole.
5. Place spring pin No. 2 through hole between chisel assembly by using hammer to tap spring pin No. 2 into it.
6. Place chisel cap over chisel head and align holes from chisel cap and chisel assembly.
7. Place spring pin No. 1 through hole between chisel cap and chisel assembly by using hammer to tap spring pin No. 1 into it.

NEW DISARMING ASSEMBLY WITH KIT NO. 2

1. Place disarming assembly into defuzing tool body.
2. Align four holes of disarming assembly with holes from defuzing tool body.
3. Place four machine screws with nuts and locking washers into holes by using 3/8-inch hex key wrench. Rotate clockwise (to right) until screw is fully seated with base of disarming assembly.
4. Repeat step above for assembling new chisel assembly.

BAIL HANDLE

1. Place bail handle on top of defuzing tool body.
2. Align five handle screw holes with holes in defuzing tool body.
3. Place five handle screws into holes by using 1/8-inch hex key wrench. Rotate clockwise (to right) until screw is fully seated with base of bail handle.

SOCKET HEAD CAP SCREW AND QUICK RELEASE PINS

1. Place socket head cap screw into ring of connecting wire of quick release pins.
2. Align and place socket head cap screw into side of defuzing tool body.
3. Rotate socket head cap screw clockwise (to right) by using 3/16-inch hex key wrench until screw is fully seated.
4. Place two quick release pins into side of defuzing tool body.

FRONT AND REAR MOUNTING BRACKETS (known as Front and Rear Supports)

1. Place front mounting bracket (with a larger radius cut) on bottom of defuzing tool body.
2. Place two screws through base of defuzing tool body by using 3/16inch hex key wrench until screws are fully seated.
3. Using same procedure as above, assemble back mounting bracket.

REPAIR BREECH PLUG TOOL

1. Drive remaining pin(s) into body of tool and sink them in as far as possible using a drive pin punch.
2. Drive new pin using drive pin punch until 3/32 inch is exposed.

CHAPTER 4 MAINTENANCE INSTRUCTIONS

SECTION I. WEAPON

Refer to TM 9-1015-249-10, Operator's Manual for Mortar, 81mm: M252; TM 9-1015-200-10, Operator's Manual for Mortar 81mm: M29A1; TM 91015-254-13&P, 81mm Subcaliber Insert; or TM 9-1015-250-10, Operator's Manual for Mortar, 120mm Towed M120 and Mortar, 120mm Carrier Mounted M121, as applicable.

SECTION II. AMMUNITION

Refer to chapter 2 of this manual.

SECTION III. MORTAR DEFUZING TOOL, BREECH PLUG TOOL

Refer to chapter 3 of this manual.

73/(74 blank)

APPENDIX A REFERENCES

ARMY REGULATIONS

Report of Transportation Discrepancies in Shipments	AR 55-38
Defense Traffic Management Regulation	AR 55-355
Engineering for Transportability	AR 70-47
Malfunctions Involving Ammunition and Explosives	AR 75-1
Accident Reporting and Records	AR 385-40
Policies and Procedures for Firing Ammunition for Training, Target Practice and Combat	AR 385-63
Integrated Logistic Support.....	AR 700-127

FIELD MANUALS

The Field Artillery Observer	FM 6-30
Tactical Employment of Mortar	FM 7-90
Mortars	FM 23-90
Mortar Gunnery	FM 23-91

FORMS

U.S. Army Accident Report	DA Form 285
Recommended Changes to Publications and Blank Forms	DA Form 2028
Weapon Record Data.....	DA Form 2408-4
DOD Fire Incident Report.....	2324
DOD Summary No Loss Fire Emergencies Report.....	2324-1
Transportation Discrepancy Report	SF 361
Report of Discrepancy (ROD)	SF 364

MISCELLANEOUS PUBLICATIONS

Instructions for Preparing the Integrated Logistic Support Plan.....	DA PAM 700-55
The Army Maintenance Management System (TAMMS)	DA PAM 738-750
Physical Security of Sensitive Conventional Arms, Ammunition, and Explosives	DOD 5100.76M

TECHNICAL PUBLICATIONS

Operator's Manual for Mortar, 81mm: M29A1.....	TM 9-1015-200-10
Operator's Manual for Mortar, 81mm: M252.....	TM 9-1015-249-10

Operator's Manual for Mortar, 120mm Towed M120 and Mortar, 120mm Carrier-Mounted M121	TM 9-1015-250-10
81mm Subcaliber Insert	TM 9-1015-254-13&P
Operator's and Unit Maintenance Manual for Cartridge, 81mm: Target Practice (Short Range), M880	TM 9-1315-252-12&P

FIRING TABLE

Mortar, 81mm: M29A1 and M252; Firing Cartridge (SR) M880	FT 81-AR-1, C4
--	----------------

APPENDIX B
REPAIR PARTS AND SPECIAL TOOLS LIST

Section I. INTRODUCTION

1. SCOPE . This RPSTL lists and authorizes spare and repair parts and other support equipment required for performance of operations and unit maintenance of cartridge, 81mm: Target Practice (Short Range), M880. It authorizes the requisitioning issue, and disposition of spares and repair parts as indicated by the source, maintenance and recoverability (SMR) codes.

2. GENERAL In addition to Section I, Introduction, this Repair Parts List is divided into the following sections:
 - a. Section II Repair Parts List A list of spares and repair parts authorized by the KFPSTL for use in the performance of maintenance. The list also includes parts which must be removed for replacement of the authorized parts. Parts lists are composed of functional groups in ascending alphanumeric sequence. Items listed are shown on associated illustrations. Kits are listed

separately and contain necessary support equipment for a mortar platoon to recover and refurbish (maintain) expended cartridges.

- b. Section III Special Tools List Not applicable
- c. Section IV Cross Reference Indexes - A list of National Stock numbers in National Item identification number (NIIN) sequence, of all National Stock numbered items appearing in listings, followed by an alphanumeric part numbers listings.

3.EXPLANATION OF LISTING

- a. National Stock Numbers and/or part numbers, descriptions and quantities are provided to assist the mortar platoon on requisitioning the proper ammunition parts and equipment.
- b. Brief explanation of Source Maintenance and Recoverability (SMR) codes the SMR code contains supply requisitioning information maintenance level authorization criteria, and disposition instruction, as shown in the following breakout:

Source Code

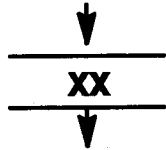

How you get an item

Maintenance Code

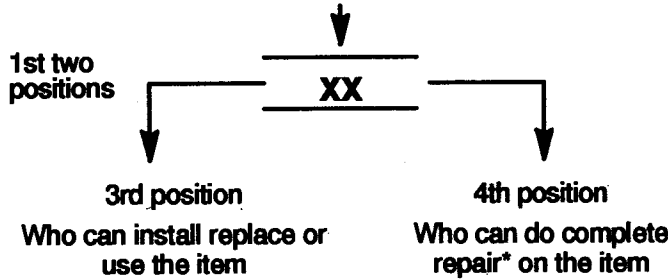

Recoverability Code

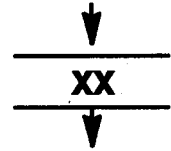

Who determines disposition action on an unserviceable item

section II. REPAIR PARTS AND SPECIAL TOOLS LIST

(1)	(2)	(3)	(4)	(5)	(6)
ITEM NO	SMR CODE	CAGEC	PART NUMBER	DESCRIPTION AND USABLE ON CODES(UOC)	QTY
				GROUP 00 FIGURE B1. CARTRIDGE, 81MM: TARGET PRACTICE M880 (19200) 12630929	
1	PDOZZ	19200	12929721	TOOL KIT AMMUNITION: ..Block, cartridge (1) B2-1 ..Brush cleaning (1) B2-2 ..Brush, wire, scratch (2) B2-3 ..Defuzing tool, mortar: (known as Defuzing device) (1) B2-23 ..Face, hammer, inserted (2) B2-4 ..Gloves, chemical and oil protective: (rubber) (3) B2-5 ..Gloves: (leather) (6) B2-6	1

(1)	(2)	(3)	(4)	(5)	(6)
ITEM NO	SMR CODE	CAGEC	PART NUMBER	DESCRIPTION AND USABLE ON CODES(UOC)	QTY
				GROUP 00 FIGURE B1. (cont.) CARTRIDGE, 81MM: TARGET PRACTICE M880 (19200) 12630929	
				..Goggles, Industrial	(6) B2-7
				..Hammer, hand: (ball- peen)	(1) B2-8
				..Holder, inserted hammer face	(1) B2-9
				..Pin, straight, headless	(12)B2-10
				..Pliers, slip joint	(1) B2-11
				..Puller, mechanical: (Recovery assembly, lower)	(2) B2-12
				..Punch, drive pin	(1) B2-13
				..Punch, drive pin: (for ignition cartridge removal)	(1) B2-14
				83	

(1)	(2)	(3)	(4)	(5)	(6)
ITEM NO	SMR CODE	CAGEC	PART NUMBER	DESCRIPTION AND USABLE ON CODES(UOC)	QTY
GROUP 00 FIGURE B1. (cont.)					
CARTRIDGE, 81MM: TARGET					
PRACTICE M880					
(19200) 12630929					
				Rod, cleaning, small arms	(2) B2-15
				Screwdriver, flat tip	(1) B2-16
				Shipping and storage container: M592	(1) B2-17
				Staff section, cleaning: (intermediate)	(2) B2-18
				Staff section, cleaning: (end)	(2) B2-19
				Tool, breech plug	(2) B2-20
				Wrench, pipe	(1) B2-21
				Wrench, spanner: (known as 81mm fin wrench)	(1) B2-22

(1)	(2)	(3)	(4)	(5)	(6)
ITEM NO	SMR CODE	CAGEC	PART NUMBER	DESCRIPTION AND USABLE ON CODES(UOC)	QTY
GROUP 0001 FIGURE B2. TOOL KIT, AMMUNITION (19200)12929721					
1	PAOZZ	19200	12556125	Block, cartridge: 60mm/81mm	1
				Part of kit PIN 12929721	
2	PAOZZ	19205	7162132	Brush cleaning small arms:	1
				Part of kit P/N 12929721	
3	PAOZZ	72915	8078883	Brush, wire, scratch:	2
				Part of kit P/N 12929721	
4	PAOZZ	76732	26N	Face, hammer, inserted: 2-1/2"	
				face dia, medium hard	2
				Part of kit PIN 12929721	
5	PAOZZ	81348	ZZ-G-381	Gloves, chemical and oil	
				protective: (rubber)	3
				Part of kit P/N 12929721	
6	PAOZZ	81349	MIL-G-2366	Gloves: (leather).....	6
				Part of kit P/N 12929721	

(1)	(2)	(3)	(4)	(5)	(6)
ITEM NO	SMR CODE	CAGEC	PART NUMBER	DESCRIPTION AND USABLE ON CODES(UOC)	QTY
GROUP 0001 FIGURE B2. (cont.) TOOL KIT, AMMUNITION (19200)12929721					
7	PAOZZ	58536	A-A-1110	Goggles, industrial: Part of kit P/N 12929721	6
8	PAOZZ	55719	BPN32A	Hammer, hand: (ball-peen) Part of kit P/N 12929721	1
9	PAOZZ	81348	GGG-H-33	Holder, inserted hammer face: 2-1/2" dia face, 4 lbs Part of kit P/N 12929721	1
10	PAOZA	96906	MS9390-090	Pin, straight, headless: 0.094 x .375 lg (repair part to tool breech plug).....	12
11	PAOZZ	55719	HL112P	Part of kit P/N 12929721 Pliers, slip joint: Part of kit P/N 12929721	1

(1)	(2)	(3)	(4)	(5)	(6)
ITEM NO	SMR CODE	CAGEC	PART NUMBER	DESCRIPTION AND USABLE ON CODES(UOC)	QTY
GROUP 0001 FIGURE B2. (cont.)					
TOOL KIT, AMMUNITION					
(19200)12929721					
12	PAOZZ	19200	12929711	Puller, mechanical: (recovery assembly, lower) 1 of 3 parts that make up a grappling tool	2
				Part of kit PIN 12929721	
13	PAOZZ	81348	GGG-P-831	Punch, drive pin:	1
				Part of kit P/N 12929721	
14	PAOZZ	19200	12630667	Punch, drive pin: (for ignition cartridge removal)	1
				Part of kit P/N 12929721	
15	PAOZZ	19204	5564102	Rod, cleaning, small arms:	2
				Part of kit P/N 12929721	
16	PAOZZ	96508	R3322-2	Screwdriver, flat tip:.....	1
				Part of kit P/N 12929721	

(1)	(2)	(3)	(4)	(5)	(6)
ITEM NO	SMR CODE	CAGEC	PART NUMBER	DESCRIPTION AND USABLE ON CODES(UOC)	QTY
GROUP 0001 FIGURE B2. (cont.) TOOL KIT, AMMUNITION (19200) 12929721					
17	PAOZZ	19200	10542565	Shipping and storage container, cartridge: M592.....	1
18	PAOZZ	K3743	137/NM33601/SA	Part of kit P/N 12929721 Staff section cleaning: (intermediate) 1 of 3 parts that make up a grappling tool	2
19	PAOZZ	U1515	MR11106	Part of kit P/N 12929721 Staff section, cleaning: (end) 1 of 3 parts that make up a grappling tool	2
20	PAOZZ	19200	12630666	Part of kit P/N 12929721 Tool, breech plug: 60mm/81mm	2

(1)	(2)	(3)	(4)	(5)	(6)
ITEM NO	SMR CODE	CAGEC	PART NUMBER	DESCRIPTION AND USABLE ON CODES(UOC)	QTY
GROUP 0001 FIGURE B2. (cont.) TOOL KIT, AMMUNITION (19200) 12929721					
21	PAOZZ	19207	5576345	Wrench, pipe: (known as strap wrench)..... Part of kit P/N 12929721	1
22	PAOZZ	19200	12630668	Wrench, spanner: (known as 81mm fin wrench) Part of kit P/N 12929721	1
23	PAOZZ	19200	12937450	Defuzing tool, mortar: (known as Defuzing device) Part of kit P/N 12929721	1

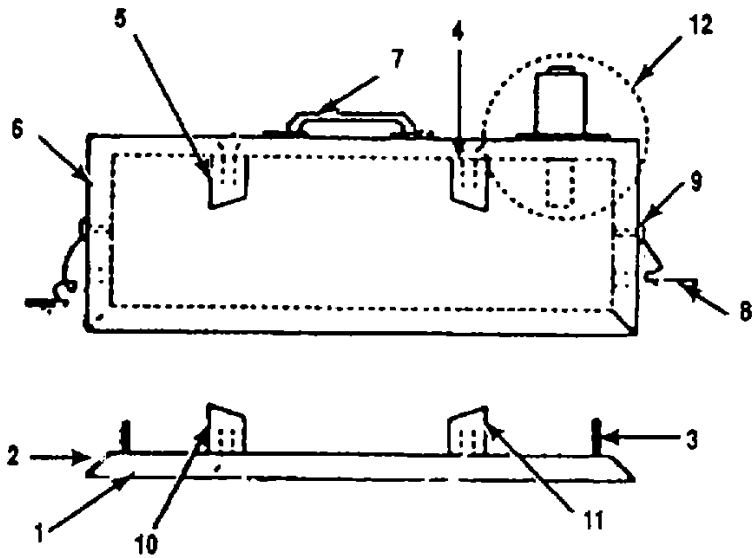

U
AR6243

FIGURE B3. DEFUZING TOOL, MORTAR (Known as Defuzing Device)

(1)	(2)	(3)	(4)	(5)	(6)
ITEM NO	SMR CODE	CAGEC	PART NUMBER	DESCRIPTION AND USABLE ON CODES(UOC)	QTY
				GROUP 000101 FIGURE B3. DEFUZING TOOL, MORTAR: (known as Defuzing Device) (19200) 12937450	
1	XAOOO	19200	12929695	Base assembly:	1
2	XAOZZ	19200	12929696	Plate, base:	1
3	XAOZZ	19200	12929698	Post, locking:	4
4	PAOZZ	19200	12929702	Bracket, mounting: (known as support, front) upper	1
5	PAOZZ	19200	12929701	Bracket, mounting: (known as support, rear) upper	1
6	XAOOO	19200	12929694	Cover assembly:.....	1
7	PAOZZ	96906	MS18012-3	Handle, bail:	1
8	PAOZZ	96906	MS17984-C616	Pin, quick release:	4
9	PAOZZ	19200	12929704	Screw, cap, socket head: 10-32 thd x 1/2 " lg	4
10	PAOZZ	19200	12929701	Bracket, mounting: (known as support, rear) lower	1

(1)	(2)	(3)	(4)	(5)	(6)
ITEM NO	SMR CODE	CAGEC	PART NUMBER	DESCRIPTION AND USABLE ON CODES(UOC)	QTY
GROUP 000101 FIGURE B3. (cont.)					
DEFUZING TOOL, MORTAR:					
(known as Defuzing Device)					
(19200) 12937450					
11	PAOZZ	19200	12929702	Bracket, mounting: (known as support, front) lower.....	1
12	XAOOO	19200	12929705	Disarming assembly:	1
13	PAOZZ	19200	12929722	Tool kit, ammunition: (Defuzing device repair parts kit #1) Not illustrated	1
14	PAOZZ	19200	12929723	Tool kit, ammunition: (Defuzing device repair parts kit #2) Not illustrated.....	1

THIS PAGE IS INTENTIONALLY LEFT BLANK

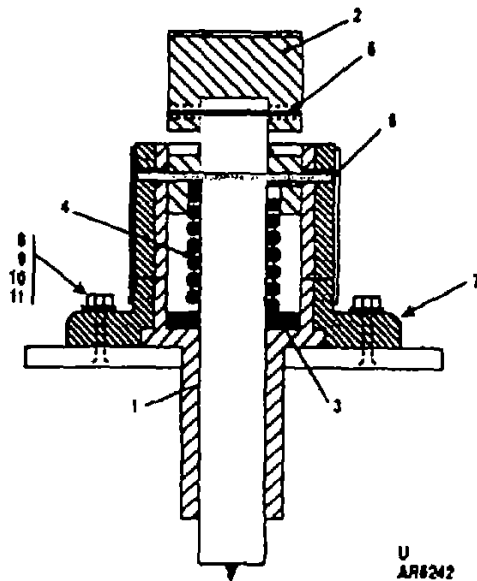

FIGURE B4. TOOL KIT AMMUNITION: KIT #1 AND KIT #2 (Defuzing Device Repair Parts for Disarming Assembly)

(1)	(2)	(3)	(4)	(5)	(6)
ITEM NO	SMR CODE	CAGEC	PART NUMBER	DESCRIPTION AND USABLE ON CODES(UOC)	QTY

GROUP 9901 FIGURE B4.

TOOL KIT AMMUNITION:

(Defuzing Device Repair Parts)

Kit #1 (19200) 12929722 (1 of 2)

- 1 Chisel assembly: (1)
(19200)12929715
- 2 Chisel cap: (1)
(19200) 12929718
- 3 Rubber, washer: (1)
(19200)12929719
- 4 Spring: (1)
(19200)12929720
- 5 Spring pin: No. 1, (1)
114 x 1-1/2 lg
(96906) MS16562-66
- 6 Spring pin: No. 2, (1)
1/4 x 2-1/2" lg
(10001) 3020984-7-40

(1)	(2)	(3)	(4)	(5)	(6)
ITEM NO	SMR CODE	CAGEC	PART NUMBER	DESCRIPTION AND USABLE ON CODES(UOC)	QTY

GROUP 9902 FIGURE B4. (cont.)

**TOOL KIT AMMUNITION:
(Defuzing Device Repair Parts)
Kit #2 (19200) 12929723 (2 of 2)**

- | | | |
|----|---|-----|
| 7 | Chisel alignment support
assembly:
(19200)12929706 | (1) |
| 8 | Nut, plain, hexagon:
3/8-16 stainless steel
(96906) MS35691-19 | (4) |
| 9 | Screw cap, socket head:
3/8-16 stainless steel
(96906) MS16995-83 | (4) |
| 10 | Washer flat: 3/8", stainless
steel
(96906) MS15795-814 | (4) |
| 11 | Washer, metal locking: 3/8"
(39428) 92146A031 | (4) |

TM 9-1315-252-12&P
CROSS-REFERENCE INDEXES
PART NUMBER INDEX

CAGEC	PART NUMBER	STOCK NUMBER	FIGURE	ITEM
58536	A-A-1110	4240-00-052-3776	B2	7
55719	BPN32A	5120-00-061-8546	B2	8
81348	GGG-H-33	5120-00-903-8551	B2	9
81348	GGG-P-831	5120-00-293-0791	B2	13
55719	HL112P	5120-00-781-0819	B2	11
81349	MIL-G-2366	8415-00-268-7870	B2	6
U1515	MR11106	1015-99-960-7160	B2	19
96906	MS15795-814		B4	10
96906	MS16562-66		B4	5
96906	MS16995-83		B4	9
96906	MS17984-C616	5315-00-007-6103	B3	8
96906	MS18012-3	5340-00-836-1938	B3	7
96906	MS35691-19		B4	8
96906	MS9390-090	5315-00-834-3468	B2	10
96508	R3322-2	5120-00-062-8454	B2	16
81348	ZZ-G-381	8415-00-641-4600	B2	5
19200	10542565	8140-01-083-9229	B2	17

CAGEC	PART NUMBER	STOCK NUMBER	FIGURE	ITEM
19200	12556125	1015-01-253-8255	B2	1
19200	12630666	5120-01-374-0892	B2	20
19200	12630667	5120-01-373-8839	B2	14
19200	12630668	5120-00-373-8832	B2	22
19200	12929694		B3	6
19200	12929695		B3	1
19200	12929696		B3	2
19200	12929698		B3	3
19200	12929701		B3	5
19200	12929701		B3	10
19200	12929702		B3	4
19200	12929702		B3	11
19200	12929704		B3	9
19200	12929705		B3	12
19200	12929706		B4	7
19200	12929711		B2	12
19200	12929715		B4	1
19200	12929718		B4	2
19200	12929719		B4	3
19200	12929720		B4	4

CAGEC	PART NUMBER	STOCK NUMBER	FIGURE	ITEM
19200	12929721	5180-01-348-3081	B1	1
19200	12929722	5180-01-348-3079	B3	13
19200	12929723	5180-01-348-3080	B3	14
19200	12937450	4925-01-354-2143	B2	23
K3743	137/NM33601/SA	1015-99-960-7161	B2	18
76732	25N	5120-00-357-5868	B2	4
10001	3020984-7-40		B4	6
19204	5564102	1105-00-556-4102	B2	15
19207	5576345	5120-00-262-8491	B2	21
19205	7162132		B2	2
72915	8078883	7920-00-291-5815	B2	3
39428	92146A031		B4	11

SECTION IV**CROSS-REFERENCE INDEXES
NATIONAL STOCK NUMBER INDEX**

STOCK NUMBER	FIG	ITEM	STOCK NUMBER	FIG	ITEM
5315-00-007-6103	B3	8	5315-00-834-3468	B2	10
4240-00-052-3776	B2	7	5340-00-836-1938	B3	7
5120-00-061-8546	B2	8	5120-00-903-8551	B2	9
5120-00-062-8454	B2	16	8140-01-083-9229	B2	17
5120-00-262-8491	B2	21	1015-01-253-8255	B2	1
8415-00-268-7870	B2	6	5180-01-348-3079	B3	13
5120-00-293-0791	B2	13	5180-01-348-3080	B3	14
5120-00-357-5868	B2	4	5180-01-348-3081	B1	1
5120-00-373-8832	B2	22	4925-01-354-2143	B2	23
1105-00-556-4102	B2	15	5120-01-373-8839	B2	14
8415-00-641-4600	B2	5	5120-01-374-0892	B2	20
1005-00-716-2132	B2	2	1015-99-960-7160	B2	19
5120-00-781-0819	B2	11	1015-99-960-7161	B2	18

**APPENDIX C
EXPENDABLE AND DURABLE ITEMS LIST**

Section I. INTRODUCTION

SCOPE

This appendix lists expendable and durable items required for refurbishment (maintenance) of Cartridge, 81mm: Target Practice (Short Range), M880.

EXPLANATION OF LISTING

National stock numbers/part numbers, descriptions and Unit of Issues (UI) are provided to assist the mortar platoon in requisitioning the required item.

Section II. EXPENDABLE AND DURABLE ITEMS LIST

(1) Item Number	(2) Level	(3) National Stock Number	(4) Description	(5) (U/M)/ (U/I)
1		9150-00-231-2361	Lubricating oil, general purpose: gl (81349) MIL-L-3150	QT
2		7920-00-205-1711	Rag, wiping (58536) A-A-2522	BE

By Order of the Secretary of the Army:

GORDON R. SULLIVAN
General, United States Army
Chief of Staff

Official:

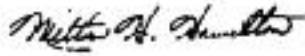

MILTON H. HAMILTON
Administrative Assistant to the
Secretary of the Army
04893

Distribution:

To be distributed in accordance with DA Form 12-40-E, Block 0860, requirements for TM 9-1315-252-12&P

*U.S. G.P.O.:1993-746-163:80709

U.S. Government Printing Office 1996 406-42161192

RECOMMENDED CHANGES TO EQUIPMENT TECHNICAL PUBLICATIONS

 <p style="font-size: small; margin: 0;"><i>THEN...JOT DOWN THE DOPE ABOUT IT ON THIS FORM. CAREFULLY TEAR IT OUT, FOLD IT AND DROP IT IN THE MAIL.</i></p>		SOMETHING WRONG WITH PUBLICATION	
		FROM: (PRINT YOUR UNIT'S COMPLETE ADDRESS)	
		DATE SENT	
PUBLICATION NUMBER		PUBLICATION DATE	PUBLICATION TITLE
BE EXACT PIN-POINT WHERE IT IS			
PAGE NO.	PARA-GRAPH	FIGURE NO.	TABLE NO.
IN THIS SPACE, TELL WHAT IS WRONG AND WHAT SHOULD BE DONE ABOUT IT.			
PRINTED NAME, GRADE OR TITLE AND TELEPHONE NUMBER			SIGN HERE

The Metric System and Equivalents

Linear Measure

1 centiliter = 10 milliliters = .34 fl. ounce
 1 centimeter = 10 millimeters = .39 inch
 1 decimeter = 10 centimeters = 3.94 inches
 1 meter = 10 decimeters = 39.37 inches
 1 dekameter = 10 meters = 32.8 feet
 1 hectometer = 10 dekameters = 328.08 feet
 1 kilometer = 10 hectometers = 3,280.8 feet

Square Measure

Weights

1 sq. centimeter = 100 sq. millimeters = .155 sq. inch
 1 centigram = 10 milligrams = .15 grain
 1 decigram = 10 centigrams = 1.54 grains
 1 gram = 10 decigram = .035 ounce
 1 decagram = 10 grams = .35 ounce
 1 hectogram = 10 decagrams = 3.52 ounces
 1 kilogram = 10 hectograms = 2.2 pounds
 1 quintal = 100 kilograms = 220.46 pounds
 1 metric ton = 10 quintals = 1.1 short tons
 1 cu. centimeter = 1000 cu. millimeters = .06 cu. inch
 1 cu. decimeter = 1000 cu. centimeters = 61.02 cu. inches
 1 cu. meter = 1000 cu. decimeters = 35.31 cu. feet

Liquid Measure

1 deciliter = 10 centiliters = 3.38 fl. ounces
 1 liter = 10 deciliters = 33.81 fl. ounces
 1 dekaliter = 10 liters = 2.64 gallons
 1 hectoliter = 10 dekaliters = 26.42 gallons
 1 kiloliter = 10 hectoliters = 264.18 gallons

1 sq. decimeter = 100 sq. centimeters = 15.5 sq. inches
 1 sq. meter (centare) = 100 sq. decimeters = 10.76 sq. feet
 1 sq. dekameter (are) = 100 sq. meters = 1,076.4 sq. feet
 1 sq. hectometer (hectare) = 100 sq. dekameters = 2.47 acres
 1 sq. kilometer = 100 sq. hectometers = .386 sq. mile

Cubic Measure

Approximate Conversion Factors

<i>To change</i>	<i>To</i>	<i>Multiply by</i>	<i>To change</i>	<i>To</i>	<i>Multiply by</i>
inches	centimeters	2.540	ounce-inches	Newton-meters	.007062
feet	meters	.305	centimeters	inches	.394
yards	meters	.914	meters	feet	3.280
miles	kilometers	1.609	meters	yards	1.094
square inches	square centimeters	6.451	kilometers	miles	.621
square feet	square meters	.093	square centimeters	square inches	.155
square yards	square meters	.836	square meters	square feet	10.764
square miles	square kilometers	2.590	square meters	square yards	1.196
acres	square hectometers	.405	square kilometers	square miles	.386
cubic feet	cubic meters	.028	square hectometers	acres	2.471
cubic yards	cubic meters	.765	cubic meters	cubic feet	35.315
fluid ounces	milliliters	29.573	cubic meters	cubic yards	1.308
pints	liters	.473	milliliters	fluid ounces	.034
quarts	liters	.946	liters	pints	2.113
gallons	liters	3.785	liters	quarts	1.057
ounces	grams	28.349	liters	gallons	.264
pounds	kilograms	.454	grams	ounces	.035
short tons	metric tons	.907	kilograms	pounds	2.205
pound-feet	Newton-meters	1.356	metric tons	short tons	1.102
pound-inches	Newton-meters	.11296			

Temperature (Exact)

°F	Fahrenheit	5/9 (after	Celsius
temperature	subtracting 32)	temperature	°C

